

Lt Col Zsolt Végyvári:

## SUPERCAPACITORS AND THEIR MILITARY APPLICABILITY

DOI: [10.35926/HDR.2019.1-2.3](https://doi.org/10.35926/HDR.2019.1-2.3)

**ABSTRACT:** *There are several types of the electrical power devices that are hardly known outside professional circles. One of them is the supercapacitor, which is very interesting attributable to its capabilities. Given its parameters, it can be considered unique, thus, its use in some special equipment is indispensable. With the spread of electricity, there will be more and more military equipment in which currently there is no alternative to its use. It is therefore well worth learning a bit more about it.*

**KEYWORDS:** *capacitor, supercapacitor, electrical energy storage*

### SUMMARY OF CONVENTIONAL CAPACITORS AND THEIR FEATURES

Before starting to elaborate on supercapacitors, it is also worth reviewing the major features of traditional capacitors as these are more or less the same. Capacitors are electro-technical components that have been known for a long time. The first such device was the well-known Leyden jar. This was built by the German physicist, Ewald Georg von Kleist and the Dutch physicist working at the University of Leiden, Pieter van Musschenbroek independently from each other in 1745<sup>1</sup>. This was the first device with the help of which static electricity could be stored. Thus, this device can be considered to be the antecedent of all power storage devices. The ancestor of the modern capacitors, the paper capacitor had already appeared by the late 1800s. By the 20<sup>th</sup> century, capacitors had become an integral part of everyday life attributed to the revolutionary developments taking place in the fields of electro-technology, electronics and microelectronics. Although it is not widely known, hundreds of such devices can be found in an average household either in the form of discrete circuit elements or integrated into a circuit board. Before moving on, I enclose a brief overview of physical quantities and their units used in the present paper:

Physical quantity	Symbol	SI unit
voltage	U	Volt (V)
electric current	I	Ampere (A)
electric charge	Q	Coulomb (C)

<sup>1</sup> Young, G. "Leyden jar". *Encyclopedia Britannica (online)*. 16 May 2013. <https://www.britannica.com/technology/Leyden-jar>. Accessed on 19 January 2018.

Physical quantity	Symbol	SI unit
resistance	R	Ohm ( $\Omega$ )
capacitance	C	Farad (F)
energy	W	Joule (J)
power	P	Watt (W)
speed	V	meters per second (m/s)
mass	M	kilogram (kg)

The structure of the capacitor is rather simple as it consists of two electrical conductors, called plates and an insulating layer between them, called dielectric medium [2, p. 141]. If these plates are connected to direct voltage, they become charged, and the magnitude of the electric charges accumulated on the plates is proportional to the magnitude of voltage. The (DC) equation describing this goes as (1):  $Q=CU^2$  [2, p. 140], which clearly shows that capacitance<sup>3</sup> is the major feature of such devices, namely a sort of proportionality factor between voltage and the quantity of charge. The more charge it can take at lower and lower voltage, the higher the capacitance is. If this is examined in terms of geometrical design, the bigger the surface of the plates is and the closer these plates are located to one another without leakage (i.e. the better the dielectric constant (insulating capacity) of the insulating layer is), the higher the value of capacitance is. The magnitude of capacitance can be deduced from equation (1) (2):  $C=Q/U$  (2).

The capacity of conventional, the so-called ‘dry’ capacitors used in practical electronics is merely pF and nF ( $10^{-12}$  and  $10^{-9}$  Farad). Although it was patented in 1928<sup>4</sup>, it was not until the 1970s that electrolyte capacitors, in which one of the plates was a conductive liquid called electrolyte, began to spread. Owing to the electrolyte, these devices are polarized, so these can only be used in DC circuits, but in terms of magnitude their capacitance exceeds that of dry capacitors and falls in the  $\mu\text{F}$  range ( $10^{-6}$  or one millionth Farad). The current energy of the capacitors is (3):  $W = \frac{1}{2}CU^2$ , that is to say, high energy goes with high voltage and capacitance. This already hints at the fact that the magnitude of energy stored by the largest devices with the highest capacitance manufactured for electronic purposes is only a few Joule making them unsuitable for providing the energy needed for the amount of work done.

Although the complete model of real capacitors is more complex, it is sufficed to include the below simple model as we are analysing only DC energy conditions. This model will prove to be useful later on:

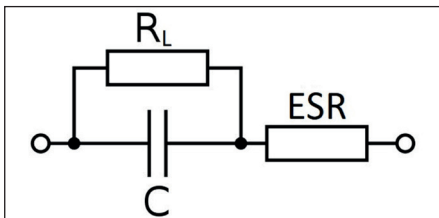

Figure 1: *The simplified DC energy model of a capacitor (by the author)*

<sup>2</sup> Gergely I. *Elektrotechnika*. Budapest: General Press, 2006.

<sup>3</sup> The applicable term is ‘capacity’, and the term ‘capacitor’ is derived from this.

<sup>4</sup> Dubilier, W. “*Electric Condenser*”, US Patent no. 468787.

In the model, the symbol  $R_L$  represents the imperfection of the dielectric medium. If a charged capacitor is left alone leakage of charge occurs through the dielectric medium. The resulting leakage current  $I_L$  slowly discharges the capacitor. ESR symbolizes the loss of energy experienced in the case of the intended discharge of the battery or in the form of increased temperature upon charging.

## A HISTORICAL OVERVIEW OF SUPERCAPACITORS<sup>5</sup> AND THE PHYSICS BEHIND

First in the 1950s, General Electric was experimenting with porous carbon electrodes to develop traditional capacitors, batteries and fuel cells as the coiled surface of the carbon electrodes formed an extremely large surface, which proved to be highly beneficial in these devices. In a certain double-layer constellation, extraordinarily increased capacitance was detected. In 1957, a patent was also issued, but its true significance was not recognized at that time and the experiments were discontinued<sup>6</sup>. In 1966, Standard Oil of Ohio staff continued the work, and even though they wanted to develop fuel cells, they already realized the potential for energy storage lying in this technology<sup>6</sup>. Eventually, the first laboratory instruments appeared in the 1970s, but it was not until the turn of the millennium that the production technology reached the level which made the technology available for the general public.



Figure 2: A typical commercially available supercapacitor (Source: lerablog.org)

About 80-90% of the commercially available supercapacitors belong to the category of electrical double layer capacitors, i.e. EDLC<sup>7</sup>. The active carbon layer deposited on the electrodes and the electrolyte – given compact sizes – provide higher performance than the conventional capacitors do<sup>8</sup>. Later on, I will compare the supercapacitors and their direct rival technology, the batteries. It is important to note that in EDLCs charges are stored with the help of chemicals, but only in a physical way, and in contrast to the batteries, there are no chemical transformations involved. The reason why this has been pointed out is that in the case of other forms of supercapacitors, the so-called pseudo-capacitors, this distinction is no

<sup>5</sup> Besides the term ‘supercapacitor’, the terms ‘ultracapacitor’, ‘supercap’ and ‘goldcap’ are also used in the English language literature.

<sup>6</sup> Katsuhiko, N. and Simon, P. “New Materials and New Configurations for Advanced Electrochemical Capacitors”. *Electrochemical Society Interface* 17/1. 2008. 34-37.

<sup>7</sup> Electric Double Layer Capacitor

<sup>8</sup> Zhong, C. *Electrolytes for electrochemical supercapacitors*. Boca Raton: CRC Press, 2016.

longer obvious. In this case, the redox<sup>9</sup> processes taking place on the surface of the carbon layer help bind charges<sup>8</sup>.

Some experts think that with the developments in the near future besides keeping the beneficial features of the supercapacitors, low self-discharge and high-power density properties of batteries can also be reached<sup>10</sup>. In this article, it would not be fortunate to make predictions in this respect, so I will only examine the currently available supercapacitor technology.

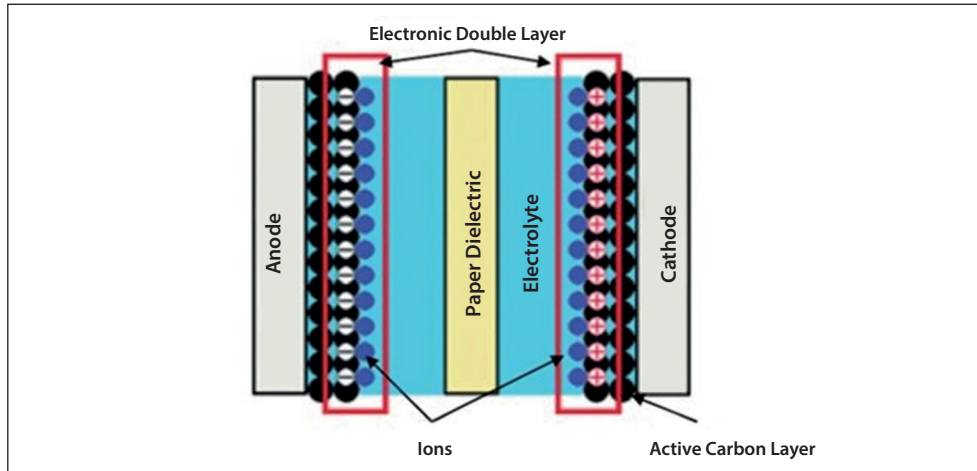

Figure 3: The structure of EDLC (Source: RS Components Hungary)

## A COMPARISON OF SUPERCAPACITORS AND BATTERIES

In order to be able to find the place of supercapacitors among the various modes of power storage, they need to be compared with the most common available technology, namely with batteries. As it has been mentioned above, chemical processes take place in batteries when charging or discharging<sup>11</sup>. These processes, however, are never 100% as electrodes wear out, the battery ages, and loses capacity during each and every charge-discharge cycle<sup>12</sup>. A battery can be regarded as depleted, if its capacity falls below 80% of the nominal value. This varies from one battery technology to another, but this generally occurs after 103 cycles. In contrast, the aging of capacitors based on physical processes is minimal, generally with a lifetime of at least 106 cycles. As opposed to physical processes, chemical processes are highly dependent on the temperature of the environment. It is a well-known fact that while the parameters of batteries deteriorate in line with the decrease of temperature, capacitors are

<sup>9</sup> Reduction – oxidation

<sup>10</sup> Guerra, M. “Can Supercapacitors Surpass Batteries for Energy Storage?” *Electronic Design*, 16 August 2016. <http://www.electronicdesign.com/power/can-supercapacitors-surpass-batteries-energy-storage>, Accessed on 22 January 2018.

<sup>11</sup> The dry battery is an electrochemical storage device, but as there is only one cycle, this technology cannot be regarded as a direct rival to supercapacitors.

<sup>12</sup> Végvári Zs. “Akkumulátorok a gyalogos lövészkatónak felszerelésében, a fejlesztés lehetséges irányai”. *Műszaki Katonai Közlöny* 26/2. 2016. 85-101. [https://mkk.uni-nke.hu/document/mkk-uni-nke-hu/2016\\_2\\_007\\_Vegvari%20Zsolt.pdf](https://mkk.uni-nke.hu/document/mkk-uni-nke-hu/2016_2_007_Vegvari%20Zsolt.pdf)

significantly less susceptible to this, in the case of certain types the temperature/ capacitance graph is basically a straight line.

Despite the above-mentioned non-beneficial properties, the market of electric storage devices is still dominated by batteries. There are two reasons for this: one being that the energy density (i.e. the energy that can be stored in unit mass or volume) of batteries largely exceeds that of the supercapacitors, and the other being the self-discharge. To explain this, the model shown in Figure 1 should be invoked and applied to electrochemical storage devices. The magnitude of the leakage current in the case of batteries and supercapacitors follows a voltage-dependent and temperature-dependent curve, but while in the case of batteries it usually takes months for the charge to drop below 80%, in the case of supercapacitors it is usually a matter of hours<sup>13</sup>.

It is the dimension of power density (i.e. how much power it can deliver at a given moment) in which supercapacitors perform very well. To understand this, we need to look at the model in Figure 1 again. When charging and discharging, the device has a so-called internal resistance, in other words, equivalent serial resistance (ESR). This resistance needs to be overcome by the charging and discharging current. For batteries, this value is typically around 100mΩ, whereas for supercapacitors this value falls between 100μΩ and 1mΩ (for the time being let us calculate with the least beneficial value of 1mΩ). Let us suppose, that our devices (one battery and one supercapacitor) are charged to the same voltage value level (now let this be 2V) and discharged with 0.1, then 1, 10, and 100A.

Applying Ohm's law, the voltage on the internal resistance can be calculated as follows (4):  $U=IR$ , and the thermal dissipation on the resistance is (5):  $P=IU$ . If relation (4) is inserted into the latter, one ends up having the relation (6):  $P=I^2R$ . If the generated heat output is entered into a table, the below can be seen:

Table 1: *Thermal dissipation at various discharging currents in a battery and in an EDLC (by the author)*

	ESR	Current	0,1A	1A	10A	100A
Battery	100mΩ	Thermal Dissipation	1mW	100mW	1W	1kW
EDLC	1mΩ		10μW	1mW	100mW	10W

It is even more interesting, if one takes a look at how much voltage out of the nominal voltage of 2V falls on the internal resistance and the load:

Table 2: *Voltage on internal resistance at various discharging currents in a battery and in an EDLC (by the author)*

	ESR	Current	0,1A	1A	10A	100A
Battery	100mΩ	Voltage at ESR	10mV	100mV	1V	–
EDLC	1mΩ		100μV	1mV	10mV	100mV

It can be clearly seen that if higher performance is required from the device, the battery starts to warm up drastically, and less and less voltage is delivered to the load. In this case, 100A cannot be obtained from the 2V cell, whereas the supercapacitor – besides tolerable

<sup>13</sup> Yu, A., Chabot, V. and Zhang, J. *Electrochemical supercapacitors for energy storage and delivery: fundamentals and applications*. Boca Raton, FL: CRC Press, 2013.

loss of heat – can still supply the load with 1.9V. It is also true that the battery under 1A constantly maintains 1.9V until total discharge while the voltage of the supercapacitor continuously decreases.

What if we want to charge our devices? The faster we want to charge a device, the bigger charging current we use. While in the case of the battery voltage higher than the nominal value has to be switched on due to the big internal resistance, the supercapacitor can practically be charged with the nominal voltage. The increase of charging current and that of the voltage are hindered by the fact that the high temperature generated by dissipation damages the device. As a result, charging batteries is a quite time-consuming process.

The chargeability of the supercapacitor is hardly limited by dissipation, due to meagre internal resistance one can expect a linear charging curve, and the following formula can be applied: (7):  $I=C*dU/dt$  [8, p. 284]. Assuming that our supercapacitor is 100 Farad and is charged with 10A, its voltage increases by 100 mV per second, thus it can be charged within 20 seconds. If 100A charging current is applied, the duration of charging is altogether 2 seconds.

Table 3: *A comparative overview of basic battery and EDLC technologies (by the author)*

Equipment		Cubage-related Energy Density	Mass-related Energy Density	Power Density	Temperature Dependency	Life-time	Self-discharge
Battery	Pb acid	100-150 kJ/l	90-100 kJ/kg	150-200 W/kg	significant	500 cycles	4-6% per month
	NiCd, NiMH	500-1000 kJ/l	30-500 kJ/kg	200-1000 W/kg	very strong	1-2000 cycles	20-30% per month
	Li-ion	2000-2500 kJ/l	800-1000 kJ/kg	300-350 W/kg	very strong	500-1500 cycles	2-3% per month
	LiFePO <sub>4</sub>	6-700 kJ/l	3-400 kJ/kg	150-200 W/kg	significant	2-4000 cycles	3-4% per month
EDLC	porous graphene	5-700 kJ/l	30-40 kJ/kg	10-15 kW/kg	minimal	10 <sup>5</sup> -10 <sup>6</sup> cycles <sup>14</sup>	5-25% per hour
	graphite-oxide <sup>15</sup>	800-1000 kJ/l	40-50 kJ/kg	15-20 kW/kg			

## MILITARY APPLICABILITY OF SUPERCAPACITORS

It can be stated that batteries are preferably to be used under circumstances where there is no possibility for charging, and besides this, in fields where it is important to store energy given the smaller mass and volume. Military applications of batteries include radio appliances, lamps or most electricity powered devices and equipment.

<sup>14</sup> Since one million cycles are difficult to interpret, and due to the short duration of cycles their use is basically constant, the duration of supercapacitors is usually given in hours, which is minimum 10,000 hours.

<sup>15</sup> The term is used in an abbreviated form, the complete name of the technology is activated microwave exfoliated graphite oxide (a-MEGO)/1-ethyl-3-methylimidazolium bis(trifluoromethylsulfonyl)imide.

Where to use supercapacitors then? In applications where the charge can more or less be maintained continuously, but at times we want to obtain enormous amounts of energy impulsively in a very short period of time. Today, in cutting edge (sometimes pilot) systems these areas of application already exist. Although it is not widely known, supercapacitors have already set their feet in military technology. Let us take a look at these systems.

## 1. Laser weapons

Laser weapons no longer exist only in science fiction. The United States, Russia and presumably China have systems with which enemy aircraft, ballistic missiles and anti-ship ballistic missiles are destroyed with a laser beam<sup>16</sup>. It is apparent that the energy needed is generated by a generator rotated by the engine of the aircraft or that of the ship, but how the energy is transmitted to the weapon. In the case of a fast-moving distant target (i.e. an aircraft, not to mention a missile), it is not possible to hold the laser beam on the target, therefore, the energy that can destroy the target must be delivered in the form of single radiation that occurs in some milliseconds. Such type of ‘firing’ laser, which does not only disrupt the navigation of the target but it also destroys it, presupposes approximately 10-100kW impulse performance. Currently, only supercapacitors are capable of accumulating electric power for a few seconds and delivering it in a matter of milliseconds.



Figure 4: USS Portland belonging to San Antonio-class will certainly be equipped with the laser (shown in the picture) developed against sea skimming anti-ship missiles<sup>17</sup>

<sup>16</sup> Ványa L. *Irányított energiájú fegyverek*. Budapest: Nemzeti Közszolgálati Egyetem, 2013.

<sup>17</sup> Insinna, V. “US Navy’s next amphibious warship to get laser weapon”, Defense News, 10 January 2018. <https://www.defensenews.com/digital-show-dailies/surface-navy-association/2018/01/10/navys-next-amphibious-warship-to-get-laser-weapon/>, Accessed on 20 January 2018.

## 2. Electromagnetically accelerated projectiles, i.e. railgun

The situation with the railgun is similar. What makes this weapon interesting is that while the laser proves to be efficient against flying objects (most of the aircrafts and the missiles are not armoured, in addition, minor damage can entirely cripple a fast-moving object), railgun is efficient against bunkers and tanks. The kinetic energy of the 12.7 kg projectile hitting the target at multiple sound speed corresponds to the impact of several kilograms of TNT<sup>18</sup>.

“The introduction of the railgun was postponed in the last minute supposedly due to financial reasons, but based on the current state of the weapon, it is already deployable and commensurate to similar-purpose conventional ship cannons in efficiency. On the basis of the published results, the ready-made railgun is capable of launching 10 HVP type projectiles per minute at an approximate 7.5 times the sound speed (7.5 Mach). This means nearly 40 MJ of muzzle energy for which – ignoring the losses – a capacitor capable of delivering minimum of 200MW electrical power is needed. Taking the planned firing speed into consideration, one charging cycle takes 5-6 seconds, and the required 40-50MW power demand puts an immense burden on the electrical system of the carrying platform. By comparison, if all electrical appliances of an average household are simultaneously switched on, only 4-6 kW is required meaning that the power demand of the railgun commensurate with that of a small town”<sup>19</sup>.

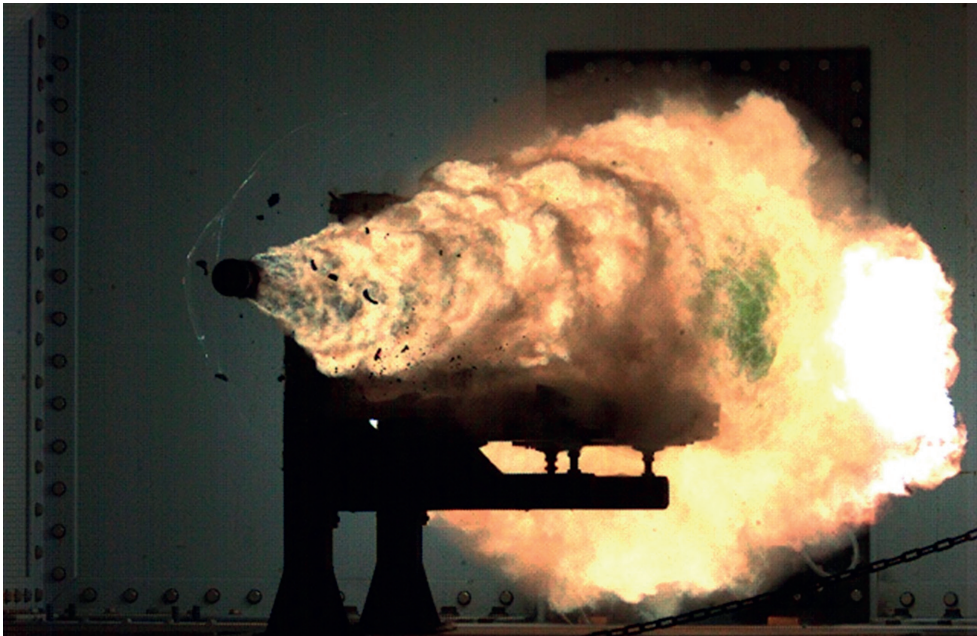

Figure 5: One of the first test shootings of the Railgun (Bae Systems)

<sup>18</sup> Végvári Zs. “Elektromágnesesen gyorsított lövedékek a tüzérség eszköztárában, A Bae Systems EM railgun-ja. 1. rész”. *Haditechnika* 51/1. 2017. 28-31. DOI: [10.23713/ht.51.1.06](https://doi.org/10.23713/ht.51.1.06)

<sup>19</sup> Végvári Zs. “Elektromágnesesen gyorsított lövedékek a tüzérség eszköztárában, A Bae Systems EM railgun-ja. 2. rész”. *Haditechnika* 51/2. 2017. 18-22. DOI: [10.23713/ht.51.2.04](https://doi.org/10.23713/ht.51.2.04)



### 3. Catapults of aircraft carriers

Experts from the few countries deploying aircraft carriers have been long waiting for the introduction of the electromagnetic catapult because the currently used steam catapult has many weaknesses. The steam powered catapult is very big in size, rather heavy, and a very complicated system. For seawater is an extremely aggressive corrosion agent, the necessary steam is developed from desalinated water, and desalination is a very energy-intensive process. The system is supplied with the steam from the turbines, thus there is no need for heating a separate boiler, but constant level of pressure must be maintained in the system to ensure preparedness, moreover, between two launches it takes quite a lot of time for the system to reach the proper level of steam pressure again. Power needed for the aircraft of various weights can only be roughly controlled, and the enormous pulling force puts a big strain on the structure of the aircrafts. In addition to this, the high-pressure hot steam runs the high risk of causing accidents, plus the system also has high maintenance needs<sup>20</sup>.

The latest super aircraft carrier of the United States, the USS Gerald Ford (CVN-78), currently undertaking its sea trials, is equipped with electromagnetic launch units or systems (EMALU or EMALS<sup>21</sup>) replacing the steam catapult. Despite the many initial problems, in principle, these are free of the shortcomings of the steam catapult. Here, the energy needed for the launch is stored kinetically in huge rotating rotors. It is obvious that research and development will be focused on the possible substitution of mechanical parts with high space and maintenance needs<sup>22</sup>.



Figure 6: USS Gerard Ford with EMALS (General Atomics)

<sup>20</sup> Allamadani, R. and Chen, F. “Electromagnetic Aircraft Launching Unit (EMALU)”. Presentation. ASEE 2014 Zone, Bridgeport, 2014.

<sup>21</sup> Electromagnetic Launch Unit/System

<sup>22</sup> Yu, Chabot and Zhang. *Electrochemical supercapacitors for energy storage and delivery...*

## 4. Vehicle drive train

More and more experts are dealing with hybrid and purely electricity driven vehicles. At the current level of technology, only batteries can store the energy needed in such vehicles, but supercapacitors can improve a few parameters of the system. As it has been pointed out earlier, at a higher load the loss of batteries significantly grows, thus, in theory a supercapacitor functioning as a buffer can have beneficial effects on the efficiency of the system<sup>23</sup>.

As the energy density and power density of the batteries deteriorate at low temperatures, a buffer supercapacitor would provide the starting current needed for the cold-start of a conventional diesel engine. The so-called hybrid batteries produced for such purposes are currently available<sup>24</sup>.



Figure 7: *The well-proven Oshkosh HEMTT is also available with electric drive (TruckTrend)*

The American Oshkosh Corporation known for its military vehicles went even further. The newest, electricity powered version of the HEMTT<sup>25</sup> military vehicle – first produced 35 years ago – has been available in its product range since 2011. HEMTT A3 is equipped with a 470LE Cummins diesel engine, which does not only drive the wheels but it also drives a 340kW generator which constantly charges a series of supercapacitors of 1.9 MJ nominal capacitance, and drives four AC engines of 480V (one per each axle) through an inverter<sup>26</sup>.

<sup>23</sup> Mihalczuk, M., Grzesiak, L. M. and Ufnalski, B. “A lithium battery and ultracapacitor hybrid energy source for an urban electric vehicle”. *Przegląd Elektrotechniczny* 88/4. 2012. 158-162.

<sup>24</sup> “Maxwell Technologies Engine Starting Module”. Maxwell Technologies. <http://www.maxwell.com/esm/default.aspx>, Accessed on 22 January 2018.

<sup>25</sup> Heavy Expanded Mobility Tactical Truck

<sup>26</sup> Thompson, J. “The Diesel-Electric Hybrid HEMTT A3 Lean by OSHKOSH – Diesel Power Magazine”. *Truck Trend*. 1 July 2011. <http://www.trucktrend.com/cool-trucks/1107dp-diesel-electric-hybrid-hemtt-oskosh-a3/>, Accessed on 28 November 2017.

Oshkosh claims that the ProPulse version consumes 20% less fuel than the diesel driven version with the same capacity, but this is not the most remarkable novelty of the system. With the help of the supercapacitor, the ProPulse is suitable for supplying military facilities, communication stations, military medical units, etc. with medium-level consumption needs, but it is also capable of launching a 120kW electric power-impulse making it an ideal platform for radars, land-based laser or railgun weapon systems.

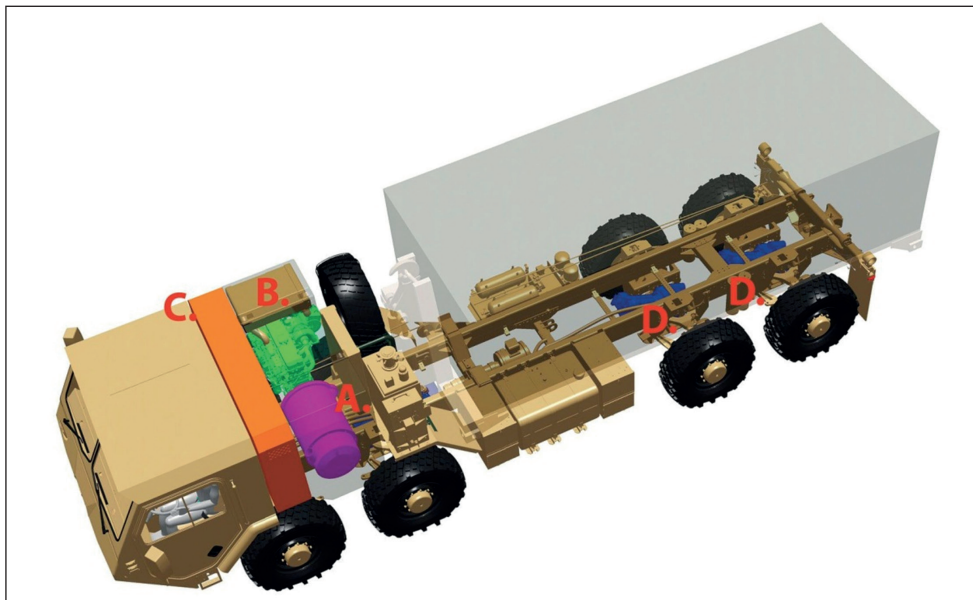

Figure 8: *The structure of HEMTT ProPulse (A – generator, B – diesel engine, C – supercapacitors, D – AC engines, TruckTrend)*

## CONCLUSION

Today it is not always the military research and development that represents the leading edge of innovation. It is sufficed to take the smart devices, IoT, or electromobility as an example. Society's ever-growing demand for electric power and desire for mobility are a lot stronger than the demand of the armies. As a consequence, one of the most intensely researched fields of science has been the storage of electric power. Everyone wants to have a storage device, which has properties such as huge capacity, high power output and increased resistance to the cold. At this moment, it cannot be foreseen if there will be batteries capable of power output similar to that of supercapacitors, or there will be supercapacitors with higher capacity and with the ability of staying charged for months. Hybrid batteries may spread. It is certain that supercapacitors are already here, and other technologies are not suitable for meeting special military needs at the moment. In all likelihood, supercapacitors will be more frequently used in the armed forces in the future.

## BIBLIOGRAPHY

- Allamadani, R. and Chen, F. "Electromagnetic Aircraft Launching Unit (EMALU)". Presentation. ASEE 2014 Zone, Bridgeport, 2014.
- Dubilier, W. "Electric Condenser". US Patent no. 468787.
- Gergely I. *Elektrotechnika*. Budapest: General Press, 2006.
- Guerra, M. "Can Supercapacitors Surpass Batteries for Energy Storage?". *Electronic Design*, 16 August 2016. <http://www.electronicdesign.com/power/can-supercapacitors-surpass-batteries-energy-storage>, Accessed on 22 January 2018.
- Insinna, V. "US Navy's next amphibious warship to get laser weapon". Defense News, 10 January 2018. <https://www.defensenews.com/digital-show-dailies/surface-navy-association/2018/01/10/navys-next-amphibious-warship-to-get-laser-weapon/>, Accessed on 20 January 2018.
- Katsuhiko, N. and Simon, P. "New Materials and New Configurations for Advanced Electrochemical Capacitors". *Electrochemical Society Interface* 17/1. 2008. 34–37.
- "Maxwell Technologies Engine Starting Module". Maxwell Technologies. <http://www.maxwell.com/esm/default.aspx>, Accessed on 22 January 2018.
- Mihalczuk, M., Grzesiak, L. M., and Ufnalski, B. "A lithium battery and ultracapacitor hybrid energy source for an urban electric vehicle". *Przegląd Elektrotechniczny* 88/4. 2012. 158–162.
- Thompson, J. "The Diesel-Electric Hybrid HEMTT A3 Lean by OSHKOSH – Diesel Power Magazine". Truck Trend, 1 July 2011. <http://www.trucktrend.com/cool-trucks/1107dp-diesel-electric-hybrid-hemtt-oskosh-a3/>, Accessed on 28 November 2017.
- Ványa L. *Irányított energiájú fegyverek*. Budapest: Nemzeti Közszolgálati Egyetem, 2013.
- Végyvári Zs. "Akkumulátorok a gyalogos lövészkatonák felszerelésében, a fejlesztés lehetséges irányai". *Műszaki Katonai Közlemény* 26/2. 2016. 85–101. [https://mkk.uni-nke.hu/document/mkk-uni-nke-hu/2016\\_2\\_007\\_Vegvari%20Zsolt.pdf](https://mkk.uni-nke.hu/document/mkk-uni-nke-hu/2016_2_007_Vegvari%20Zsolt.pdf)
- Végyvári Zs. "Elektromágnesesen gyorsított lövedékek a tüzérség eszköztárában, A Bae Systems EM railgun-ja. 1. rész". *Haditechnika* 51/1. 2017. 28–31. DOI: [10.23713/ht.51.1.06](https://doi.org/10.23713/ht.51.1.06)
- Végyvári Zs. "Elektromágnesesen gyorsított lövedékek a tüzérség eszköztárában, A Bae Systems EM railgun-ja. 2. rész". *Haditechnika* 51/2. 2017. 18–22. DOI: [10.23713/ht.51.2.04](https://doi.org/10.23713/ht.51.2.04)
- Young, G. "Leyden jar". In *Encyclopedia Britannica (online)*. 16 May 2013. <https://www.britannica.com/technology/Leyden-jar>, Accessed on 19 January 2018.
- Yu, A., Chabot, V. and Zhang, J. *Electrochemical supercapacitors for energy storage and delivery: fundamentals and applications*. Boca Raton, FL: CRC Press, 2013.
- Zhong, C. *Electrolytes for electrochemical supercapacitors*. Boca Raton: CRC Press, 2016.